

GP 20-35UX

2,000kg / 2,500kg / 3,000kg / 3,500kg

Diesel, LPG and Dual Fuel Forklift Trucks



SPECIFICATION SHEET

Models: GP 20UX, GP 25UX, GP 30UX, GP 35UX

Truck Dimensions

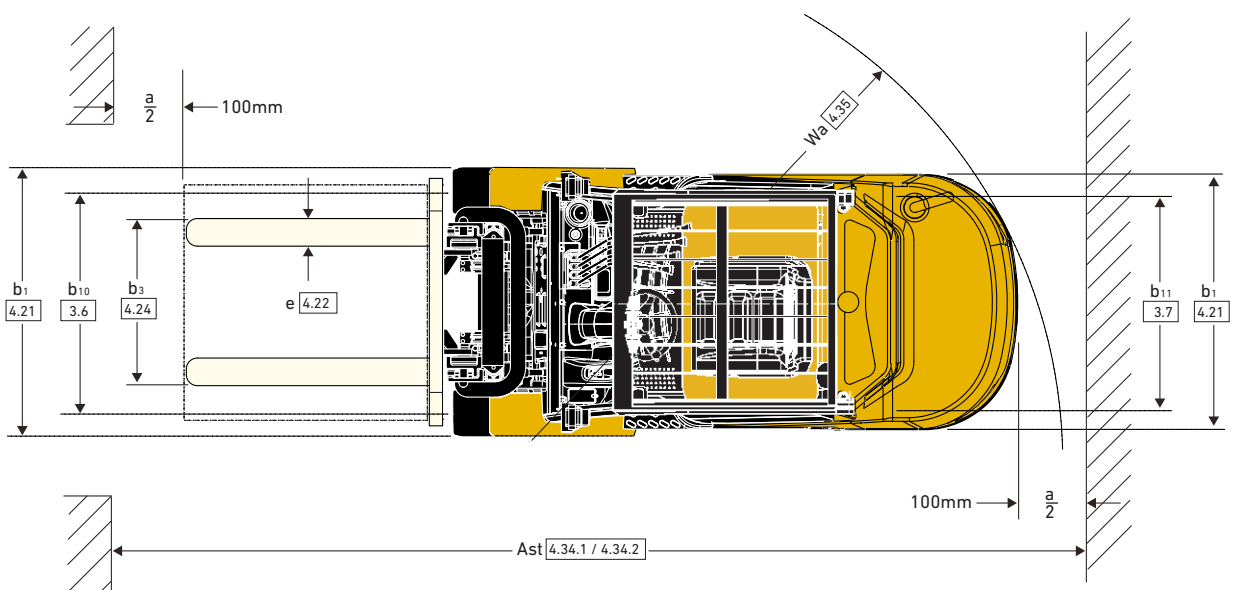
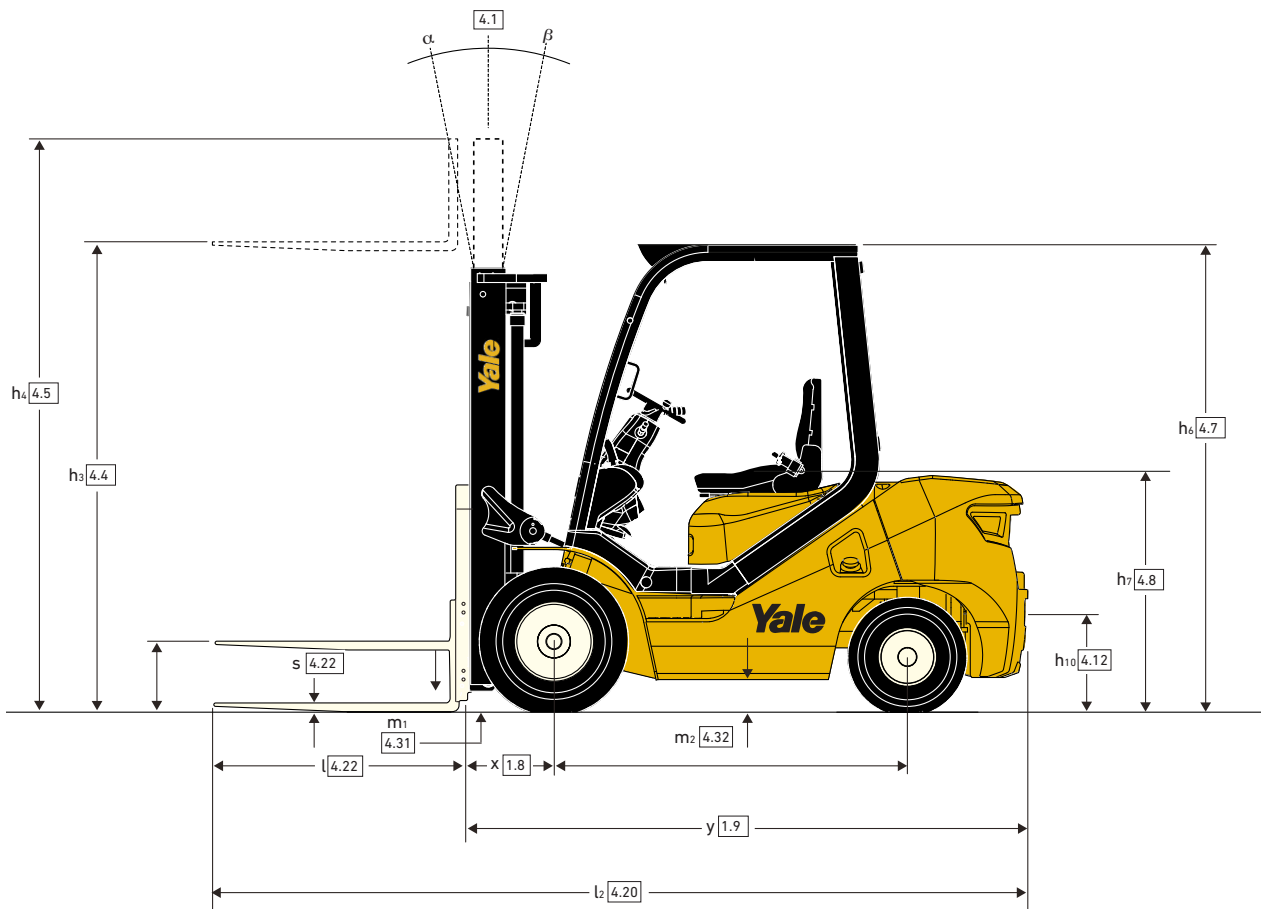

GP 20UX Mast details and capacity ratings (kg) - Superelastic tyres

Mast type	Maximum Fork Lift (mm)	Lowered Height (mm)	Lift Height without LBR (mm)	Lift Height with LBR (mm)	Free Lift without LBR (mm)	Free Lift with LBR (mm)	Load Distance (mm)	Mast Tilt F° B°	Weight, 500mm LC Single Tyre (kg)	Weight, 500mm LC Dual Tyres (kg)
2 stage LFL	3000	2010	3575	3990	160	160	465	6 12	2000	-
	3300	2160	3875	4290	160	160	465	6 12	2000	-
	3700	2360	4275	4690	160	160	465	6 6	2000	-
3 stage FFL	4500	2060	5017	5490	1440	1070	485	6 6	1600	1800
	4800	2160	5317	5790	1540	1170	485	6 6	1250	1700
	5500	2425	6017	6490	1800	1430	485	3 6	900	1400

GP 25UX Mast details and capacity ratings (kg) - Superelastic tyres

Mast type	Maximum Fork Lift (mm)	Lowered Height (mm)	Lift Height without LBR (mm)	Lift Height with LBR (mm)	Free Lift without LBR (mm)	Free Lift with LBR (mm)	Load Distance (mm)	Mast Tilt F° B°	Weight, 500mm LC Single Tyre (kg)	Weight, 500mm LC Dual Tyres (kg)
2 stage LFL	3000	2010	3575	3990	160	160	465	6 12	2500	-
	3300	2160	3875	4290	160	160	465	6 12	2500	-
	3700	2360	4275	4690	160	160	465	6 6	2500	-
3 stage FFL	4500	2060	5017	5490	1440	1070	485	6 6	2000	2300
	4800	2160	5317	5790	1540	1170	485	6 6	1700	2000
	5500	2425	6017	6490	1800	1430	485	3 6	1200	1600

GP 30UX Mast details and capacity ratings (kg) - Superelastic tyres

Mast type	Maximum Fork Lift (mm)	Lowered Height (mm)	Lift Height without LBR (mm)	Lift Height with LBR (mm)	Free Lift without LBR (mm)	Free Lift with LBR (mm)	Load Distance (mm)	Mast Tilt F° B°	Weight, 500mm LC Single Tyre (kg)	Weight, 500mm LC Dual Tyres (kg)
2 stage LFL	3000	2075	3640	4100	165	165	485	6 12	3000	-
	3300	2225	3940	4400	165	165	485	6 12	3000	-
	3700	2425	4340	4800	165	165	485	6 6	3000	-
3 stage FFL	4500	2125	5100	5600	1525	1025	505	6 6	2500	2700
	4800	2225	5400	5900	1625	1125	505	6 6	2250	2450
	5500	2490	6100	6600	1880	1380	505	3 6	1650	2100

GP 35UX Mast details and capacity ratings (kg) - Superelastic tyres

Mast type	Maximum Fork Lift (mm)	Lowered Height (mm)	Lift Height without LBR (mm)	Lift Height with LBR (mm)	Free Lift without LBR (mm)	Free Lift with LBR (mm)	Load Distance (mm)	Mast Tilt F° B°	Weight, 500mm LC Single Tyre (kg)	Weight, 500mm LC Dual Tyres (kg)
2 stage LFL	3000	2150	3700	4100	170	170	505	6 12	3500	-
	3300	2300	4000	4400	170	170	505	6 12	3500	-
	3700	2500	4400	4800	170	170	505	6 6	3500	-
3 stage FFL	4500	2200	5140	5600	1560	1100	520	6 6	2800	3000
	4800	2300	5440	5900	1660	1200	520	6 6	2500	2750
	5500	2565	6140	6600	1915	1455	520	3 6	1800	2300

Engine Specifications

Yanmar 2.6L, Diesel		Yanmar 3.0L, Diesel		Yanmar 3.3L, Diesel		GCT 2.5L, LPG/Dual Fuel*		Mitsubishi 3.3L, Diesel**	
4 Cylinder	Overhead valve	4 Cylinder	Overhead valve	4 Cylinder	Overhead valve	4 Cylinder	Overhead valve	4 Cylinder	Overhead valve
Displacement	2.6 litre	Displacement	3.0 litre	Displacement	3.3 litre	Displacement	2.4 litre	Displacement	3.3 litre
Torque	138 Nm @1,500rpm	Torque	162 Nm @1,500rpm	Torque	203 Nm @1,650rpm	Torque	196 Nm @1,500rpm	Torque	118 Nm @1,650rpm
Power	33kW @2,450rpm	Power	35.5kW @2,400rpm	Power	42.1kW @2,300rpm	Power	37.4kW @2,300rpm	Power	34.4kW @2,300rpm
Air filtration	Two stage, dry type	Air filtration	Two stage, dry type	Air filtration	Two stage, dry type	Air filtration	Two stage, dry type	Air filtration	Two stage, dry type
IDI fuel injection system		IDI fuel injection system		IDI fuel injection system		IDI fuel injection system		IDI fuel injection system	

* Dual Fuel is MEA only

** For regulated regions only

VDI 2198 – General Specifications, Diesel powered GP 20UX, GP 25UX, GP 30UX, GP 35UX

		GP 20UX				GP 25UX					
		Yale	Yale	Yale	Yale	Yale	Yale	Yale	Yale		
Distinguishing mark	1.1	Manufacturer		Yale	Yale	Yale	Yale	Yale	Yale	Yale	
	1.2	Model designation		GP 20UX				GP 25UX			
	1.3	Power: battery, diesel, LPG, electric mains		Diesel	Diesel	LPG	Dual-Fuel	Diesel	Diesel	LPG	Dual-Fuel
		Engine manufacturer/type		Yanmar 2.6L	Mitsubishi 3.31L	GCT K25	GCT K25	Yanmar 2.6L	Mitsubishi 3.31L	GCT K25	GCT K25
	1.4	Operation: manual, pedestrian, stand, seat, orderpicker		Seat	Seat	Seat	Seat	Seat	Seat	Seat	
	1.5	Load capacity	Q (t)	2000	2000	2000	2000	2500	2500	2500	2500
	1.6	Load centre	c (mm)	500	500	500	500	500	500	500	500
	1.8	Load distance	x (mm)	475	475	475	475	475	475	475	475
	1.9	Wheelbase	y (mm)	1600	1600	1600	1600	1600	505	1600	1600
Weights	2.1	Unladen weight	kg	3390	3390	3390	3390	3650	545	3650	3650
	2.2	Axle loading with load front/rear	kg	4760 / 630	4760 / 630	4760 / 630	4760 / 630	5320 / 650	435	5400 / 650	5400 / 650
	2.3	Axle loading without load, front/rear	kg	1540 / 1850	1540	1540 / 1850	1540 / 1850	1500 / 2150	1500 / 2150	1500 / 2150	1500 / 2150
Tyres/chassis	3.1	Tyres: P = pneumatic, V = cushion, SE = superelastic		P	P	P	P	P	P	P	P
	3.2	Tyre size, front		7.00 x 12-12PR	7.00 x 12-12PR	7.00 x 12-12PR	7.00 x 12-12PR	7.00 x 12-12PR	7.00 x 12-12PR	7.00 x 12-12PR	7.00 x 12-12PR
	3.3	Tyre size, rear		6.00 x 9-10PR	6.00 x 9-10PR	6.00 x 9-10PR	6.00 x 9-10PR	6.00 x 9-10PR	6.00 x 9-10PR	6.00 x 9-10PR	6.00 x 9-10PR
	3.5	Number of wheels, front/rear (X = driven)		2X / 2	2X / 2	2X / 2	2X / 2	2X / 2	2X / 2	2X / 2	2X / 2
	3.6	Track width, front	b ₁₀ (mm)	970	970	970	970	970	970	970	970
	3.7	Track width, rear	b ₁₁ (mm)	980	980	980	980	980	980	980	980
	Dimensions	4.1	Mast tilt, forward α /back β	α / β (°)	6 / 12	6 / 12	6 / 12	6 / 12	6 / 12	6 / 12	6 / 12
4.2		Height of mast, lowered	h ₁ (mm)	2010	2010	2010	2010	2010	2010	2010	2010
4.3		Free lift ▲	h ₂ (mm)	160	160	160	160	160	160	160	160
4.4		Lift height ▲	h ₃ (mm)	3000	3000	3000	3000	3000	3000	3000	3000
4.5		Height of mast, extended +	h ₄ (mm)	4025	3990	4025	4025	4025	3575	4025	4025
4.7		Height to top of overhead guard ○	h ₆ (mm)	2180	2180	2180	2180	2180	3990	2180	2180
4.8		Seat height ✕	h ₇ (mm)	1167	1167	1167	1167	1167	2180	1167	1192
4.12		Towing coupling height	h ₁₀ (mm)	250	250	250	250	250	2205	250	250
4.19		Overall length	l ₁ (mm)	3630	3630	3630	3630	3690	1167	3690	3690
4.20		Length to face of forks	l ₂ (mm)	2560	2560	2560	2560	2620	1002	2620	2620
4.21		Overall width, Standard/Dual	b ₁ /b ₁	1150 / 1590	1150 / 1590	1150 / 1590	1150 / 1590	1150 / 1590	1150 / 1590	1150 / 1590	1150 / 1590
4.22		Fork dimensions	(mm)	40 / 122 / 1070	40 / 122 / 1070	40 / 122 / 1070	40 / 122 / 1070	40 / 122 / 1070	40 / 122 / 1070	40 / 122 / 1070	40 / 122 / 1070
4.23		Fork carriage to DIN 15173. Class, A / B	s/e/l (mm)	IIA	IIA	IIA	IIA	IIA	IIA	IIA	IIA
4.24		Fork carriage width ►	b ₃ (mm)	1040	1040	1040	1040	1040	1040	1040	1100
4.31		Ground clearance under mast, with load	m ₁ (mm)	125	125	125	125	125	125	125	125
4.32		Ground clearance at centre of wheelbase	m ₂ (mm)	150	150	150	150	150	150	150	150
4.34.1	Aisle width with pallets 1,000mm long x 1,200mm wide	A _{s1} (mm)	3966	3966	3966	3966	4026	4026	4026	4026	
4.34.2	Aisle width with pallets 800mm wide x 1,200mm long	A _{s1} (mm)	3766	3766	3766	3766	3826	3826	3826	3826	
4.35	Outer turning radius	W _a (mm)	2290	2290	2290	2290	2350	2350	2350	2350	
4.36	Inner turning radius	b ₁₃ (mm)	136	136	136	136	136	136	136	136	
Performance data	5.1	Travel speed with/without load	km/h	20	20 / 20	19	19	20	20 / 20	17.5	17.5
	5.2	Lifting speed with/without load	m/s	0.54	0.49 / 0.52	0.50	0.57	0.54	0.49 / 0.52	0.50	0.50
	5.3	Lowering speed with/without load	m/s	0.43	0.43 / 0.40	0.42	0.45	0.43	0.43 / 0.40	0.42	0.42
	5.5	Drawbar pull with/without load, @ 1.6km/h	N	10219 / 8589	15640 / 15640	12711 / 8589	12711 / 8589	10118 / 8259	15640 / 15640	12585 / 8259	12585 / 8259
		Drawbar pull with/without load, @ 4.8km/h	N	4879 / 7544	11960 / 11960	6872 / 7544	6872 / 7544	4879 / 7185	11960 / 11960	6872 / 7185	6872 / 7185
	5.6	Maximum drawbar pull with / without load	N	12774 / 8761	18663	16651 / 8761	16651 / 8761	12648 / 8450	18663 / 18663	16790 / 8450	16790 / 8450
	5.7	Gradeability with/without load, @ 1.6km/h	%	18.7 / 25.6	26 / 26	23.7 / 25.6	23.7 / 25.6	16.3 / 22.3	23 / 23	20.4 / 22.3	20.4 / 22.3
	5.8	Gradeability with/without load @ 4.8km/h	%	10.4 / 22.4	19 / 26	13.1 / 22.4	13.1 / 22.4	8.8 / 19.5	16 / 16	11 / 19.5	11 / 19.5
	5.9	Acceleration time with/without load	s	14 / 9	20	13 / 8	13 / 8	14 / 9	20	13 / 8	13 / 8
	5.10	Service brake		Hydraulic	Hydraulic	Hydraulic	Hydraulic	Hydraulic	Hydraulic	Hydraulic	Hydraulic
Combustion engine	7.2	Engine output, in accordance with ISO1585	kW	33	34.4	37.4	37.4	33	34.4	37.4	37.4
	7.3	Governed speed	min-1	2450	2250	2300	2300	2450	2250	2300	2300
	7.4	Number of cylinders/displacement	(-)/cm ³	4 / 2659	4 / 3331	4 / 2488	4 / 2488	4 / 2659	4	4 / 2488	4 / 2488
	7.5	Fuel consumption in accordance with VDI cycle	l/h or kg/h	2.6 / NA	NA	NA / 3.3	NA / 3.5	2.6 / NA	3331	NA / 3.5	NA / 3.5
	8.1	Drive control		Automatic	Automatic	Automatic	Automatic	Automatic	Automatic	Automatic	Automatic
Addition data	10.1	Working pressure for attachments	bar	0-175	0-175	0-175	0-175	0-175	0-175	0-175	0-175
	10.2	Oil flow for attachments ●	l/min	64	64	64	64	64	64	64	64
	10.7	Average noise level at operator's ear ★	dB(A)	84	84	84	84	84	84	84	84
	10.7.2	Guaranteed sound power 2001 / 14 / EC	dB(A)	104	104	103	103	104	104	103	103
	10.8	Towing coupling type		Pin	Pin	Pin	Pin	Pin	Pin	Pin	Pin

★ LPAZ, measured according to the test cycles and based on the weighting values contained in EN12053

▲ Bottom of Forks

✕ Full suspension seat specified

➤ Without load backrest

► Add 32mm with load backrest

○ h₆ subject to +/- 5 mm tolerance.

When full-suspension seat or cab is fitted, overhead guard height is raised by 60mm

● Variable

Yale	Yale	Yale	Yale	Yale	Yale	Yale	Yale	Yale	Yale	1.1	Distinguishing mark
GP 30UX					GP 35UX					1.2	
Diesel	Diesel	Diesel	LPG	Dual-Fuel	Diesel	Diesel	Diesel	LPG	Dual-Fuel	1.3	
Yanmar 3.0L	Yanmar 3.3L	Mitsubishi 3.31L	GCT K25	GCT K25	Yanmar 3.0L	Yanmar 3.3L	Mitsubishi 3.31L	GCT K25	GCT K25		
Seat	Seat	Seat	Seat	Seat	Seat	Seat	Seat	Seat	Seat	1.4	
3000	3000	3000	3000	3000	3500	3500	3500	3500	3500	1.5	
500	500	500	500	500	500	500	500	500	500	1.6	
490	490	490	490	490	510	510	510	510	510	1.8	
1700	1700	515	1700	1700	1700	1700	1700	1700	1700	1.9	
4300	4300	4300	4300	4300	4710	4710	4710	4710	4710	2.1	
6490 / 770	6490 / 810	6490 / 810	6490 / 810	6490 / 810	7250 / 960	7250 / 960	7250 / 960	7250 / 960	7250 / 960	2.2	
1710 / 2590	1710 / 2590	1710 / 2590	1710 / 2590	1710 / 2590	1690 / 3020	1690 / 3020	1690 / 3020	1690 / 3020	1690 / 3020	2.3	
P	P	P	P	P	P	P	P	P	P	3.1	Weights
28 x 9-15-12PR	28 x 9-15-12PR	28 x 9-15-14PR	28 x 9-15-12PR	28 x 9-15-12PR	28 x 9-15-12PR	28 x 9-15-12PR	28 x 9-15-14PR	28 x 9-15-12PR	28 x 9-15-12PR	3.2	
6.50 x 10-10PR	6.50 x 10-10PR	6.50 x 10-13PR	6.50 x 10-14PR	6.50 x 10-16PR	6.50 x 10-10PR	6.50 x 10-10PR	6.50 x 10-10PR	6.50 x 10-10PR	6.50 x 10-10PR	3.3	
2X / 2	2X / 4	2X / 2	2X / 6	2X / 8	2X / 2	2X / 2	2X/2	2X / 2	2X / 2	3.5	
1000	1000	1000	1000	1000	1000	1000	1000	1000	1000	3.6	
970	970	970	970	970	970	970	970	970	970	3.7	
6 / 12	6 / 12	6 / 12	6 / 12	6 / 12	6 / 12	6 / 12	6 / 12	6 / 12	6 / 12	4.1	
2075	2075	2075	2075	2075	2150	2150	2150	2150	2150	4.2	
165	165	165	165	165	165	165	165	165	165	4.3	
3000	3000	3000	3000	3000	3000	3000	3000	3000	3000	4.4	
4140	4140	4100	4140	4140	4140	4140	4100	4140	4140	4.5	
2205	2205	2205	2205	2205	2205	2205	2205	2205	2205	4.7	
1192	1192	1192	1192	1192	1192	1192	1192	1192	1192	4.8	
480	480	480	480	480	480	480	480	480	480	4.12	
3804	3804	3804	3804	3804	3894	3894	3894	3894	3894	4.19	
2734	2734	2734	2734	2734	2824	2824	2824	2824	2824	4.20	
1210 / 1650	1210 / 1650	1210 / 1650	1210 / 1650	1210 / 1650	1210 / 1650	1210 / 1650	1210 / 1650	1210 / 1650	1210 / 1650	4.21	
45 / 122 / 1070	45 / 122 / 1070	45 / 122 / 1070	45 / 122 / 1070	45 / 122 / 1070	45 / 122 / 1070	45 / 122 / 1070	45 / 122 / 1070	45 / 122 / 1070	45 / 122 / 1070	4.22	
IIIA	IIIA	IIIA	IIIA	IIIA	IIIA	IIIA	IIIA	IIIA	IIIA	4.23	
1100	1100	1100	1100	1100	1100	1100	1100	1100	1100	4.24	
130	130	130	130	130	130	130	130	130	130	4.31	
145	145	145	145	145	145	145	145	145	145	4.32	
4126	4126	4126	4126	4126	4210	4210	4210	4210	4210	4.34.1	
3926	3926	3926	3926	3926	4010	4010	4010	4010	4010	4.34.2	
2430	2430	2430	2430	2430	2500	2500	2500	2500	2500	4.35	
203	203	203	203	203	203	203	203	203	203	4.36	
20	18	20/20	18	18	18	18	20 / 20	18	18	5.1	
0.46	0.42	0.39 / 0.42	0.40	0.40	0.33	0.42	0.31 / 0.34	0.33	0.33	5.2	
0.38	0.4	0.40 / 0.38	0.40	0.40	0.4	0.4	0.38 / 0.36	0.40	0.40	5.3	
12875 / 9498	13553 / 9498	15771 / 15771	14720 / 14720	14720 / 14720	13516 / 9676	14191 / 9676	15215 / 15215	12732 / 9676	12732 / 9676	5.5	
8498 / 8119	7319 / 8119	11960 / 11960	11500 / 11500	11500 / 11500	8879 / 8892	8968 / 8892	11765 / 11765	6906 / 8892	6906 / 8892		
16094 / 9688	16941 / 9688	17768 / 17768	17480 / 17480	17480 / 17480	16870 / 9676	17739 / 9870	17141 / 17141	16679 / 9870	16679 / 9870	5.6	
21.2 / 22.3	21.2 / 22.3	19 / 19	19 / 19	19 / 19	16.7 / 20.7	21.2 / 22.3	17 / 17	18.7 / 22.3	18.7 / 22.3	5.7	
14 / 18	12.5 / 19	13 / 19	13 / 19	13 / 19	10.9 / 19	13 / 19	12 / 17	10 / 19.5	10 / 19.5	5.8	
12 / 8	12 / 8	20	13 / 8	13 / 8	12 / 8	12 / 8	17	14 / 9	14 / 9	5.9	
Hydraulic	Hydraulic	Hydraulic	Hydraulic	Hydraulic	Hydraulic	Hydraulic	Hydraulic	Hydraulic	Hydraulic	5.10	
35.5	42.1	34.4	37.4	37.4	35.5	42.1	34.4	37.4	37.4	7.2	
2400	2300	2250	2300	2300	2400	2300	2250	2300	2300	7.3	
4 / 3054	4 / 3319	4 / 3331	4 / 2488	4 / 2488	4 / 3054	4 / 3319	4 / 3331	4 / 2488	4 / 2488	7.4	
4.6 / NA	4.9 / NA	NA	NA / 3.5	NA / 3.5	NA / 4.6	NA / 4.9	NA	NA / 4.3	NA / 4.3	7.5	
Automatic	Automatic	Automatic	Automatic	Automatic	Automatic	Automatic	Automatic	Automatic	Automatic	8.1	
0-175	0-175	0-175	0-175	0-175	0-175	0-175	0 - 175	0-175	0-175	10.1	
64	64	64	64	64	64	64	64	64	64	10.2	
84	84	84	84	84	84	84	84	84	84	10.7	
104	104	104	103	103	104	104	104	103	103	10.7.2	
Pin	Pin	Pin	Pin	Pin	Pin	Pin	Pin	Pin	Pin	10.8	

Specification data is based on VDI 2198, with the following configuration:
Complete truck with 3000mm 2-stage limited free lift mast, standard carriage and 1070mm forks, overhead guard and standard pneumatic drive and steer tyres.

All values are nominal values and they are subject to tolerances. For further information, please contact the manufacturer.
Yale products might be subject to change without notice.

Lift trucks illustrated may feature optional equipment.
Values may vary with alternative configurations.

GP 20-35UX

Standard equipment

- **2.0 - 2.5T-**
Yanmar 2.6L Diesel, Mitsubishi 3.3L Diesel
or GCT 2.5L LPG / Dual-Fuel.
- **3.0 - 3.5T-**
Yanmar 3.0L Diesel, Mitsubishi 3.3L Diesel,
Yanmar 3.3L Diesel or GCT 2.5L LPG / Dual-Fuel
- Transmission: Powershift, 1-Speed
- Mast: 2-stage LFL 3000mm
- Carriage: 1038mm Class II or 1100mm Class II or III
- Forks: 1070 x 122 x 40mm Class II or 1070 x 122 x 45 / 50mm Class III
- Pneumatic Tyres:
Drive - 7.00x12-12PR or 28x9-15-12PR
Steer - 6.00x9-10PR or 6.50x10-10PR
- Two Function Cowl Mounted Manual Lever - Lift / Tilt
- Forward / Reverse Directional Lever
- Manual Park Brake
- Three Pedal Layout with Mechanical Inching
- Non-Suspension Seat (Vinyl) with Seat Belt
- Steering Wheel with Spinning Knob
- Power Steering and Tilt Adjustable Steering Column
- Key Switch Start
- Entry Grab Handle
- Dash Display:
Fuel Gauge (Diesel/Dual - Fuel), LCD Hour Meter,
Water Temperature / Oil Temperature /
Transmission Oil Level Warning Lights
- Mirrors
- Load Backrest
- Strobe Light (magnetically mounted)
- Audible Reverse Alarm
- LED Light Kit - 2 x Front Work, 2 x Front Turn,
Rear Turn / Tail / Brake / Reverse
- Counterweight Exhaust
- Radiator with Transmission Oil Cooler
- Cyclonic Air Filter
- Fixed Tank Bracket (LPG Trucks)
- Fuel Tank Capacity - UT20-25P = 60L, UT30-35P = 70L
- Toolbox
- Towing Pin
- Operator Manual
- 12 Months / 2000 Hours Manufacturer's Warranty
- Twin USB ports

Optional equipment

- Upswept exhaust
- Air Intake with Pre-cleaner
- 2-stage LFL and 3-stage FFL Masts
- Carriages: 1200, 1500mm (Class II - III)
- Forks: 1220mm (Class II - III)
- Integral Sideshift
- Valve and Hose Groups - 3 and 4 way
- Cab with/without Heater
- Full Suspension Seat
- Rear Work Light
- Dual Drive Wheels and Fender Extensions
- Superelastic Drive and Steer Tyres
- Rear/reversing handle

Visibility

The overhead guard has been designed to provide the operator with excellent all round visibility.

Hoses are routed to allow a clear view of the load and forks.

Operator Comfort

Operator compartment is ergonomically designed to offer a practical and comfortable working environment for the driver. A large step gives easy access.

A large LCD display provides the driver with the necessary operating information at a glance.

Adjustable steering column has a 6° range for maximum comfort.

A standard overhead guard, partial or full cabins are all available to meet different customer requirements.

The full cab has steel doors and front and rear screens with wash/wipe function with heater options also available.

LED marker lights and work lights are offered as standard, which eliminates the cost of bulb replacement.

Rear drive handle with integrated horn button mounted on the right rear guard leg is available.

Manoeuvrability

Highly responsive steering optimises manoeuvrability in confined spaces. Proven transmission provides smooth movement and changes of direction.

Dimensions of the truck ensure effective operation in most aisles without sacrificing driver comfort and visibility.

Load Handling

The robustly constructed mast provides optimal visibility with the auxiliary hoses centred on the free lift cylinder to eliminate hose twisting.

Positive hose retention and large radius bends are employed to minimise hose scuffing, maximising life.

Masts are offered with a tilt option, the tilt cylinder anchors are widely spaced to increase lateral stiffness and visibility.

A range of Class II and Class III LFL and FFL masts are available along with carriages including integrated side shift carriages to make load handling easy and convenient.

Hydraulic control

The ergonomically positioned control levers provide precise control, available with 2, 3 and 4 function hydraulics.



Optional integral side shift carriage assist precise load handling.

Reliability

The truck has a durable construction with a one piece welded frame.

Industry proven industrial engines from Yanmar for diesel trucks and GCT for LPG and dual fuel.

The Single speed Powershift transmission is well proven, reliable and efficient.

Mast tilt cylinders are sealed to minimize contamination.

Optimum performance and a long working life is ensured by using high-quality components. The efficient cooling system manages both oil and coolant temperatures providing reliability, reducing the risk of unplanned downtime.

Serviceability

Yale trucks are backed up by a 2000 hour warranty and comprehensive parts availability and are easy to maintain and service.

Access to the key components and daily checks is easy thanks to the 70° hood opening, held open with a locked gas spring.



About Yale®



Yale is a leading global manufacturer and supplier of high-quality counterbalance forklift trucks, warehouse equipment and fleet solutions. 'People, products and productivity' sums up our approach to the materials handling business. With over 140 years' experience, we are proud of our reputation as an innovative, forward-thinking manufacturer.

Yale dealerships provide flexible truck servicing solutions and are linked to one of the industry's most sophisticated parts distribution operations. You'll find support for Yale forklifts throughout the EMEA region – provided by a big regional footprint stretching through Europe, Middle East and Africa.

Materials handling for:



Automotive



Beverage



Chemical



Construction



Food



Logistics



Metals



Paper



Retail



Wood

Yale Europe Materials Handling

Centennial House, Frimley Business Park,
Frimley, Surrey GU16 7SG
United Kingdom

Tel: +44 (0) 1276 538500

Fax: +44 (0) 1276 538559

www.yale.com



Publication part no. 220990850 Rev.02 Printed in The Netherlands (0221HG) EN.

HYSTER-YALE UK LIMITED trading as Yale Europe Materials Handling.

Safety: This truck conforms to the current EU requirements.
Specification is subject to change without notice.

©2021 Yale. All rights reserved. YALE, and PEOPLE. PRODUCTS. PRODUCTIVITY, are trademarks of Hyster-Yale Group, Inc. is a registered copyright of Hyster-Yale Group, Inc. Trucks shown with optional equipment. Country of Registration: England and Wales. Company Registration Number: 02636775.